

FiWaRec® Products for DN33/DN50 Chemical Gas Systems



IT'S
YOUR SYSTEM
OPTIMIZED WITH
OUR COMPONENTS

FiWaRec® Product Catalogue
for DN33/DN50 Chemical Gas Systems



Content

Overview (different System Layouts)

- DN33 Systems.....4
- DN50 Systems.....5
- Cylinder Valves DN33 (1-1/2”) 6
- Cylinder Valves DN50 (2”) 6
- Actuators for Cylinder Valves DN33/DN50* (Type F112) 7
- Monitoring switch for solenoid actuator (Type F0150035) 9
- Solenoid Valves DN8 for Local Applications (Type F422) 10
- Pilot Hoses (Type F104) 10
- Pilot Line and other Accessories 11
- Discharge Hose DN33 (Type F107) 13
- Discharge Hose DN50 (Type F108) 14
- Check Valves for Discharge Line (Type F018/Type F019) 15
- Monitoring Devices 16
- Discharge Nozzles (Type F007) 17
- Software for Hydraulic Flow Calculation 20

Overview: FiWaRec® Products for DN33 Chemical Gas Systems

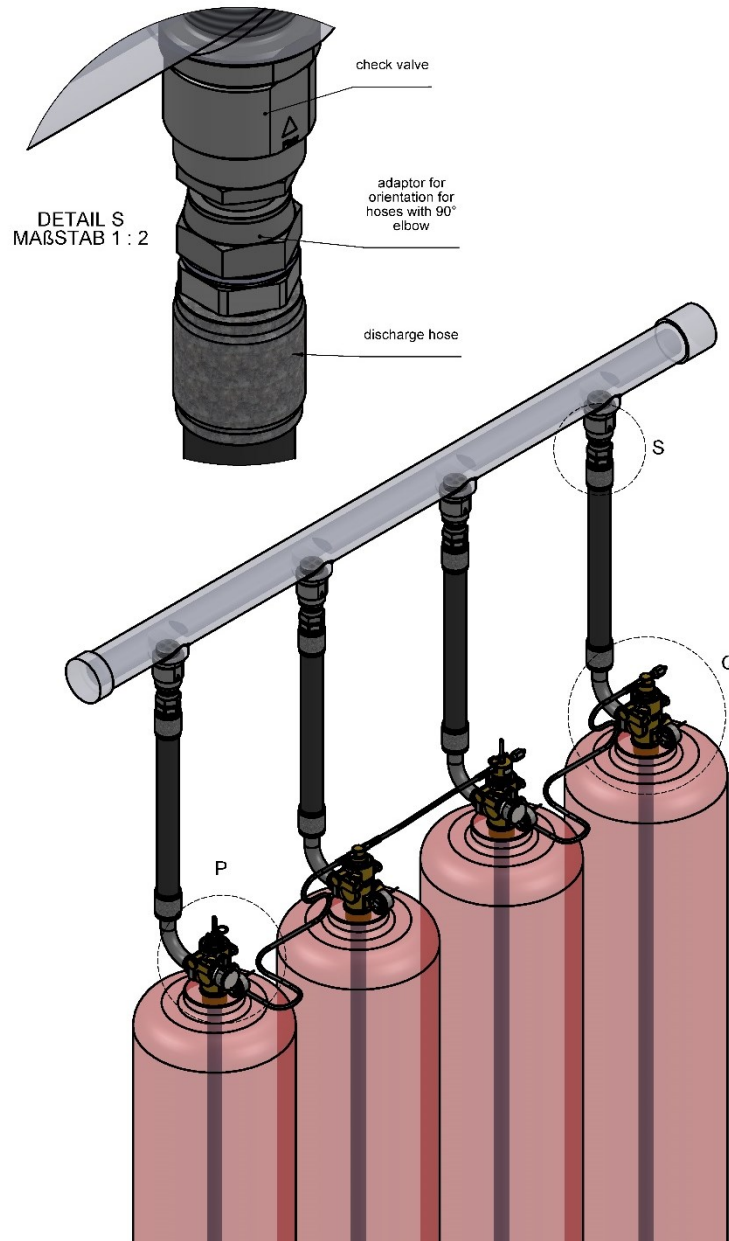

Slave Valve

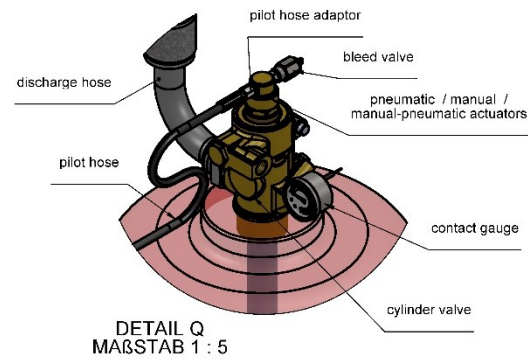

****see more detailed information about product approvals on the following pages**

Master Valve

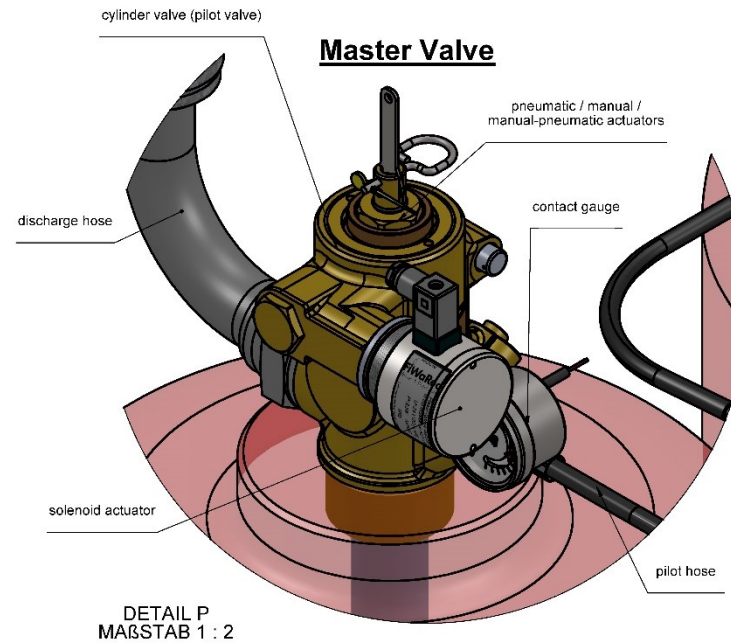

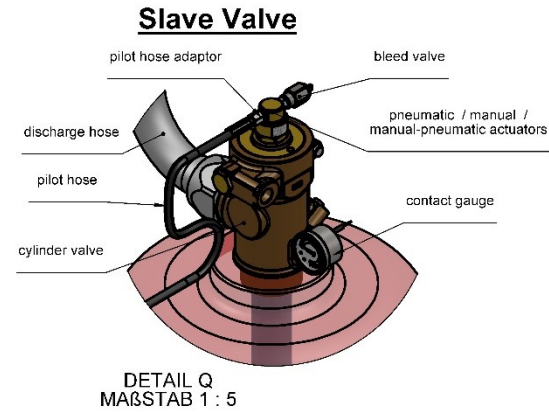
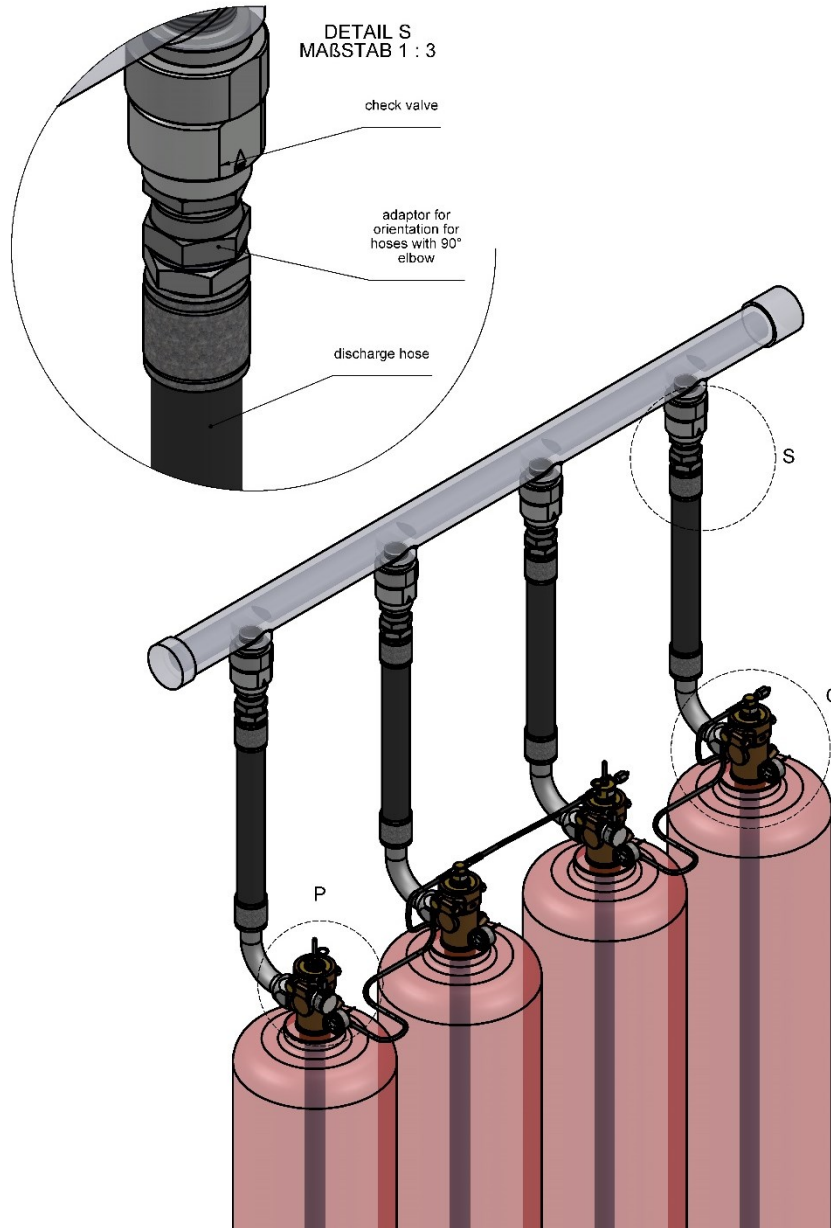

****see more detailed information about product approvals on the following pages**

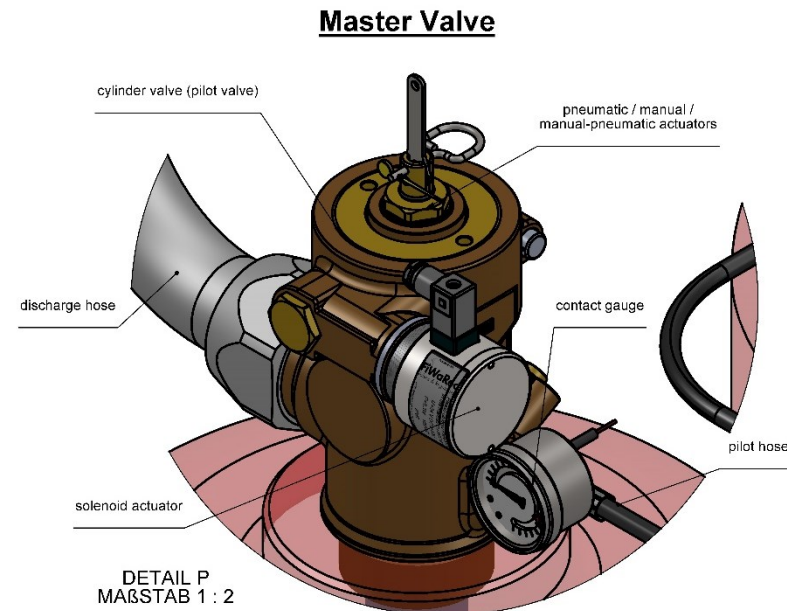

Cylinder Valves DN33 (1-1/2")

- Seat Diameter – 33mm

Type F205



Article no.	Inlet Thread	Outlet Thread	Burst Disc	Dip Tube Connection
F2050003	2,5"- 12UN-2A	1 7/8"- 12UN-3A	60bar	1,5"-16UN
F2050004			95bar	



Type F245



* these products meet the requirements of FM standards
and have been successfully tested by **FM Approvals**

Article no.	Inlet Thread	Outlet Thread	Burst Disc	Dip Tube Connection
F2450000	2,5"- 12UN-2A	1 7/8"- 12UN-3A	60bar	1,5"-16UN
F2450001			95bar	

Cylinder Valves DN50 (2")

- Seat Diameter – 50mm

Type F206



Article no.	Inlet Thread	Outlet Thread	Burst Disc	Dip Tube Connection
F2060004	3"-12UN- 2A	2,5" - 12UNJ	60bar	2,125"- 16UN
F2060005			95bar	



Type F246



* these products meet the requirements of FM standards
and have been successfully tested by **FM Approvals**

Article no.	Inlet Thread	Outlet Thread	Burst Disc	Dip Tube Connection
F2460000	3"-12UN- 2A	2,5" - 12UNJ	60bar	2,125"- 16UN
F2460001			95bar	

Actuators for Cylinder Valves DN33/DN50* (Type F112)

*see more detailed information about product approvals on the following page



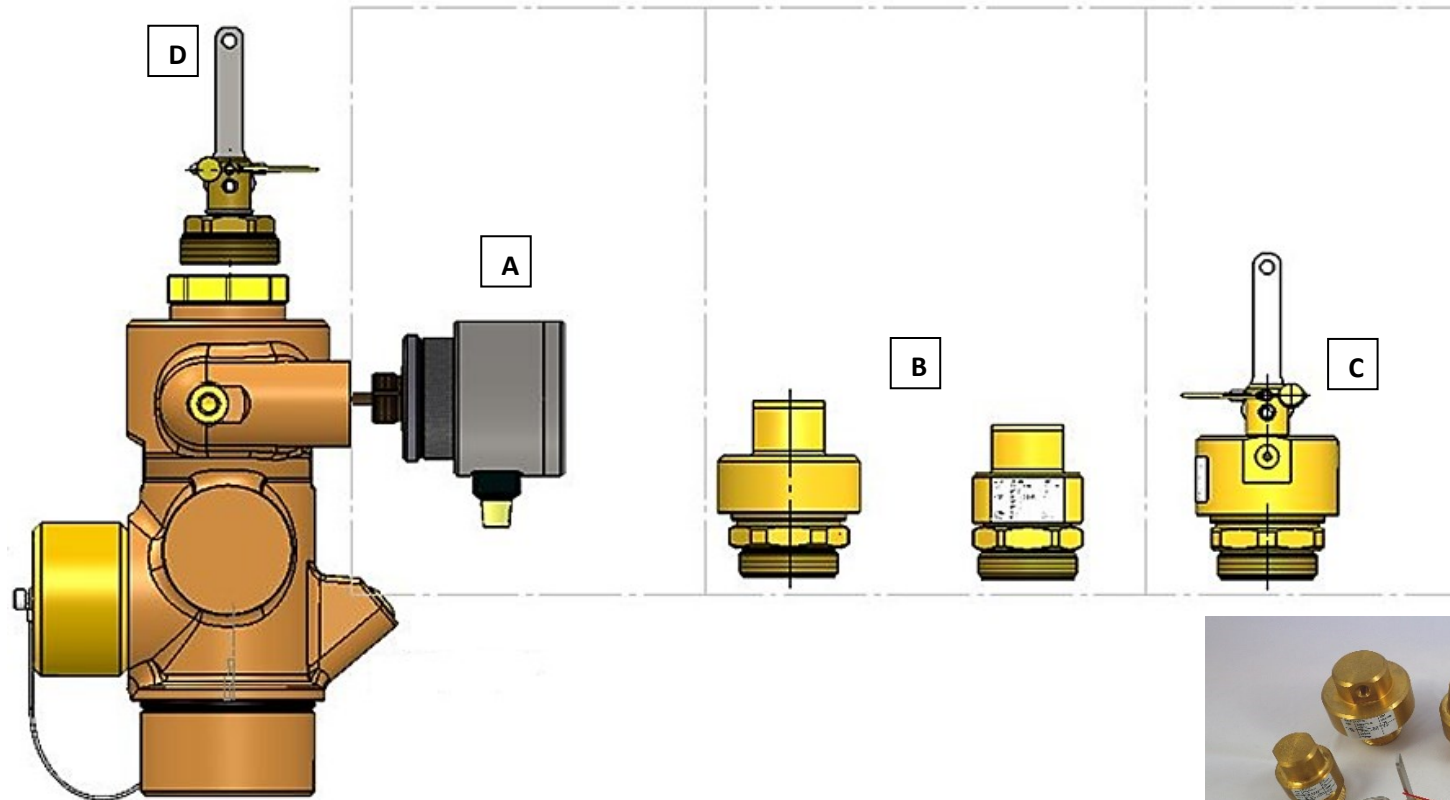

* these products meet the requirements of FM standards
and have been successfully tested by **FM Approvals**



FiWaRec® Product Catalogue
for DN33/DN50 Chemical Gas Systems



Article no.	Type	Actuation	Technical Details		Approvals
F112 0030	A	Electrical	Refer to the Instruction Manual of the Electrical Actuator for all Technical Details		
F112 0045					
F112 0005	D	Manual			 <p>* these products meet the requirements of FM standards and have been successfully tested by FM Approvals</p>
F112 0006	C	Pneumatic/ Manual	minimal (nominal) Pilot Pressure 6bar*	max. Working Pressure 300bar	
F112 0007	B	Pneumatic	minimal (nominal) Pilot Pressure 6bar*	max. Working Pressure 300bar	
F112 0011			minimal (nominal) Pilot Pressure 12bar*	max. Working Pressure 360bar	

(*) for system pressure of p1=60bar

Monitoring switch for solenoid actuator (Type F0150035)

Can be easily retrofitted to all FiWaRec® DN33 and DN50 valves

- Switching type – NO
 - Article code F0150041 alternatively as NC-type switch
- Rating – max. 30VDC, 3A
- Ingress protection class – IP67
- Wiring diagram:

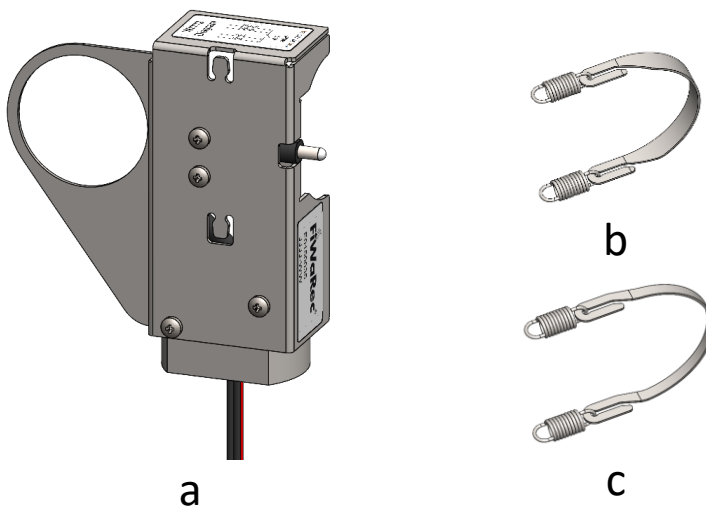
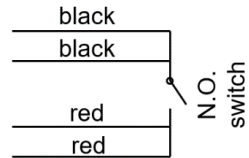

- a. monitoring device
- b. mounting clamp for use with valve F205/F245
- c. mounting clamp for use with valve F206/F246

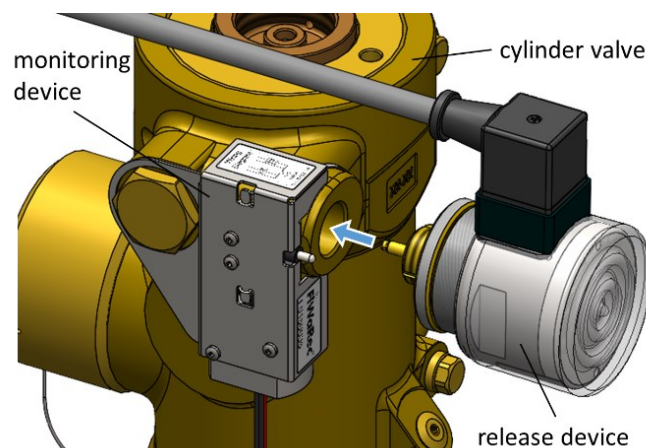

Solenoid Valves DN8 for Local Applications (Type F422)



- Seat Diameter – 8mm
- Also suitable for Powder, Foam Agents or Wet Chemicals

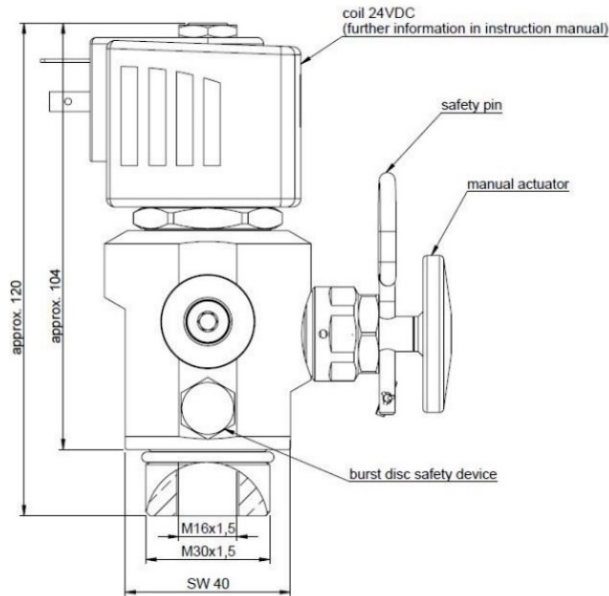

Article no.	Inlet Thread	Outlet Thread	Manual Release type	Burst Disc
F4220003	M30x1,5mm	G3/8"	Push Button	60bar
F4220005				24bar
F4220007				30bar
F4220008			Lever	30bar

Pilot Hoses (Type F104)

- Pw_{max} – 360bar
- Nominal Wide – 4mm



* these products meet the requirements of FM standards
 and have been successfully tested by **FM Approvals**



Pilot Hose F1040xxx

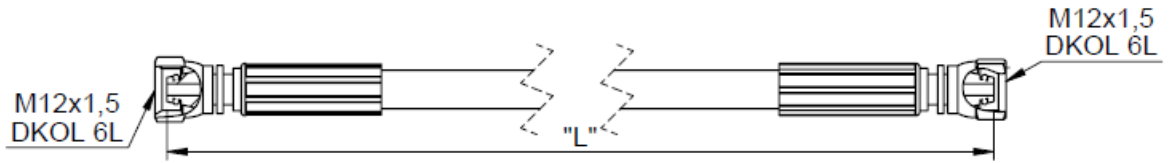

Article no.	Length "L"	Article no.	Length "L"	Article no.	Length "L"
F1040001	150mm	F1040009	550mm	F1040017	950mm
F1040002	200mm	F1040010	600mm	F1040018	1000mm
F1040003	250mm	F1040011	650mm	F1040019	1100mm
F1040004	300mm	F1040012	700mm	F1040020	1200mm
F1040005	350mm	F1040013	750mm	F1040021	1300mm
F1040006	400mm	F1040014	800mm	F1040022	1400mm
F1040007	450mm	F1040015	850mm	F1040023	1500mm
F1040008	500mm	F1040016	900mm		

*also available in excess length up to 15.000mm on request

Pilot Line and other Accessories

Adaptors for Pilot Hoses

Article no.	Type
F0010000	Straight
E6130003	T-Connector
E6130004	L-Connector
E6130005	T-Connector

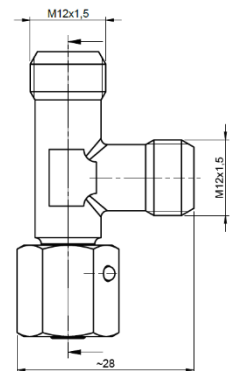
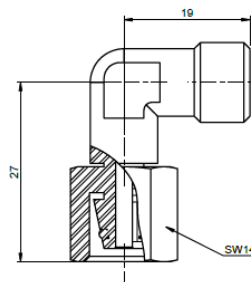
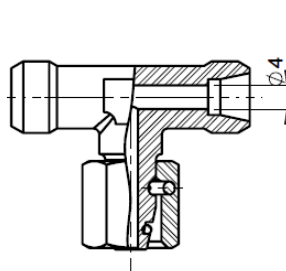
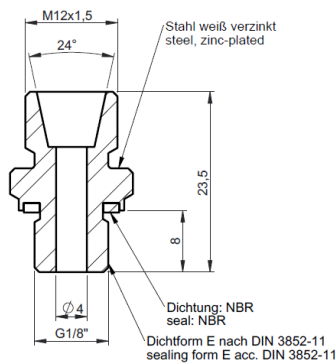

Non-Return Valve for Pilot Line F0160001

- $P_{W_{max}}$ – 360bar
- Nominal Wide – 4mm



* these products meet the requirements of FM standards
 and have been successfully tested by **FM Approvals**

flow direction / Durchflussrichtung:
 <-- open / geöffnet
 closed / geschlossen-->

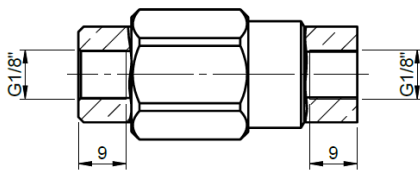

Bleed Valve (Type F0150009)

- $P_{W_{max}}$ – 360bar
- Reseating Volume Flow - ~ 30l/min
- Reseating Pressure - 0,5bar (Static) / ~ 0,7bar (Dynamic)
- Integrated Optical Control to show if the Bleed Valve is Closed (Pressurized)

*officially tested by , ,

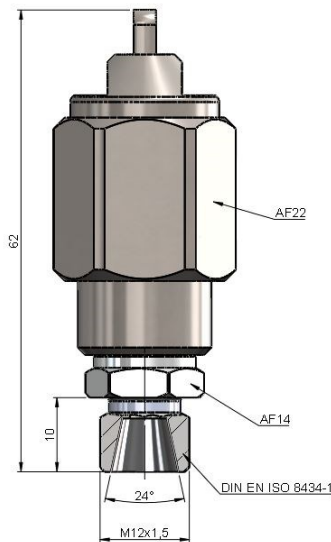

Article no.	Connection Type
F0150009	M12x1,5mm – DKOL 6L (DIN EN ISO 8434-1) – Male
F0150010	G1/8" – Male
F0150011	M12x1,5mm – DKOL 6L (DIN EN ISO 8434-1) – Female
F0150012	G1/8" – Female

* Test Report from Notified Body upon request

Vent Valve for Pilot Line (Type F0150018 /43)

- $P_{W_{max}}$ – 360bar
- To Evacuate the Pressure from the Pilot Line after Function Test or System Discharge

*officially tested by , ,

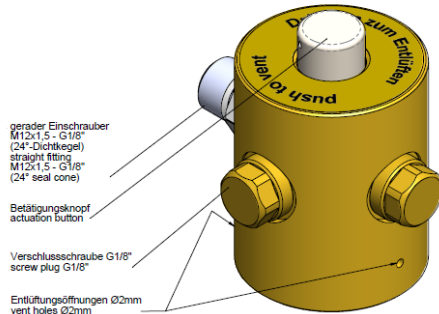

* Test Report from Notified Body upon request

Cylinder Venting Adaptor (Type F0150046)

- $P_{W_{max}}$ – 360bar
- For Safe release of cylinder pressure
 - Connection M12x1mm for gauge connection port



Discharge Hose DN33 (Type F107)

- $P_{W_{max}}$ – 70bar
- Nominal Wide – 33mm



* these products meet the requirements of FM standards and have been successfully tested by **FM Approvals**

Discharge Hose F1070xxx – 1 7/8" 12UN (female, turnable) to G1 1/2" (male)

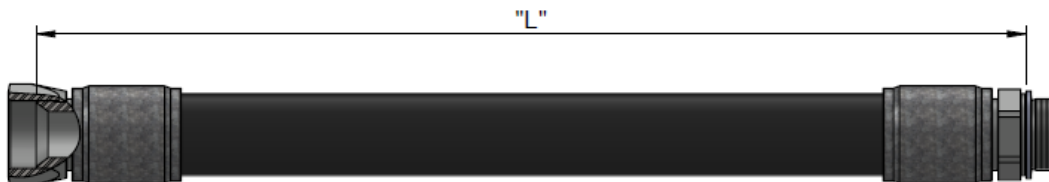

Article no.	Length "L"		Article no.	Length "L"
F1070001	300mm		F1070007	900mm
F1070002	400mm		F1070008	1000mm
F1070003	500mm		F1070009	1100mm
F1070004	600mm		F1070010	1200mm
F1070005	700mm		F1070011	1300mm
F1070006	800mm		F1070012	1400mm

Discharge Hose F1071xxx – 1 7/8" 12UN (female, turnable) to G1 1/2" (male)

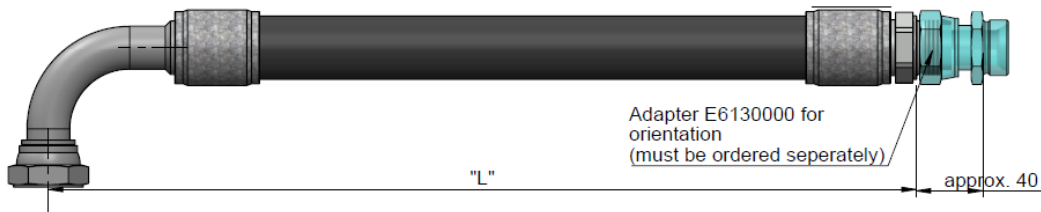

Article no.	Length "L"		Article no.	Length "L"
F1071001	350mm		F1071007	900mm
F1071002	400mm		F1071008	1000mm
F1071003	500mm		F1071009	1100mm
F1071004	600mm		F1071010	1200mm
F1071005	700mm		F1071011	1300mm
F1071006	800mm		F1071012	1400mm

Adaptor E6130000

- For Orientation of Hoses with 90°-Elbow

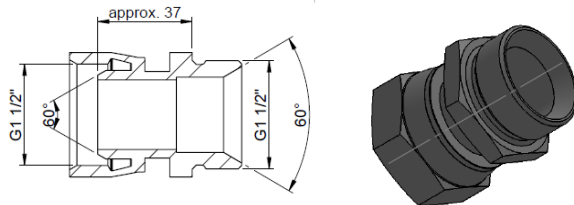

Discharge Hose DN50 (Type F108)

- Pw_{max} – 70bar
- Nominal Wide – 50mm



* these products meet the requirements of FM standards
 and have been successfully tested by **FM Approvals**

Discharge Hose F1080xxx – 2 1/2" 12UN (female, turnable) to G 2" (male)

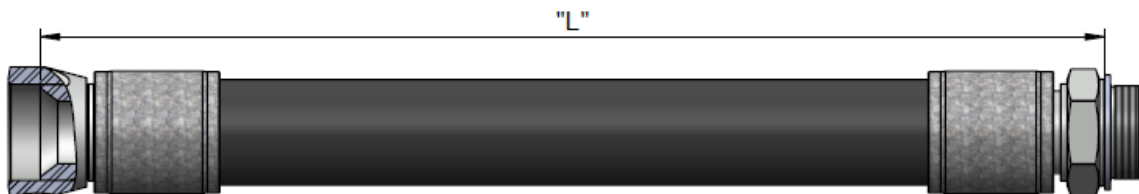

Article no.	Length "L"		Article no.	Length "L"
F1080001	340mm		F1080007	900mm
F1080002	400mm		F1080008	1000mm
F1080003	500mm		F1080009	1100mm
F1080004	600mm		F1080010	1200mm
F1080005	700mm		F1080011	1300mm
F1080006	800mm		F1080012	1400mm

Discharge Hose F1081xxx – 2 1/2" 12UN (female, turnable) to G 2" (male)

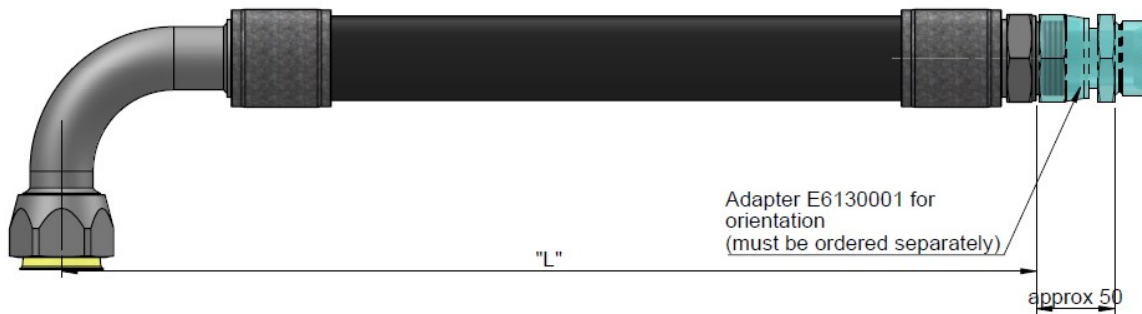

Article no.	Length "L"	Article no.	Length "L"
F1081001	400mm	F1081007	900mm
F1081002	450mm	F1081008	1000mm
F1081003	500mm	F1081009	1100mm
F1081004	600mm	F1081010	1200mm
F1081005	700mm	F1081011	1300mm
F1081006	800mm	F1081012	1400mm

Adaptor E6130001

- For Orientation of Hoses with 90°-Elbow

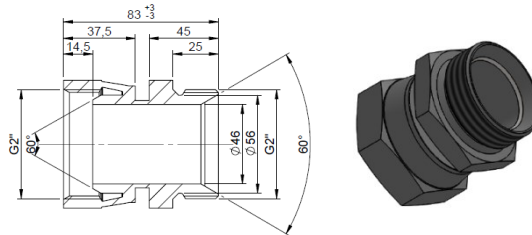

Check Valves for Discharge Line (Type F018/Type F019)

- $PW_{max} - 70bar$



* these products meet the requirements of FM standards
 and have been successfully tested by **FM Approvals**

Article no.	Nominal Wide	Inlet Thread	Outlet Thread
F0180000	50mm	G2" (female)	G2" (Male)
F0190000	33mm	G1 1/2" (female)	G2" (Male)

Monitoring Devices

Special patented Thread Connection which enables to assemble and disassemble the Gauges even under Pressure without causing any Leakages.



Pressure Gauge (Type F05200xx)

Article no.	Pressure Range
F0520006	0-100bar



Pressure Gauge (Type F05201xx)

Article no.	Pressure Range
F0520100	0-60bar
F0520101	0-100bar

Pressure Gauge with Switching Contact (Type F053)



Article no.	Pressure Range	Set Point	Switching Type*
F0530015	0-60bar	22,5bar	Normally open (NO)
F0530016			Normally closed (NC)
F0530019	0-100bar	38bar	Normally open (NO)
F0530020			Normally closed (NC)
F0530045	0-100bar	45bar	Normally open (NO)
F0530046			Normally closed (NC)



*switching type for condition without pressure



Pressure Gauge with Switching Contact (Type F058)

* these products meet the requirements of FM standards
and have been successfully tested by **FM Approvals**

Article no.	Pressure Range	Set Point	Switching Type*	Remarks
F0580004	0-60bar	22,5bar	Normally Open (NO)	only for HFC227ea
F0580005			Normally Closed (NC)	
F0580006			Normally Open (NO)	only for FK5-1-12
F0580007			Normally Closed (NC)	
F0580008	0-80bar	38bar	Normally Open (NO)	only for HFC227ea and FK5-1-12
F0580009			Normally Closed (NC)	
F0580012	0-90bar	45bar	Normally Open (NO)	
F0580013			Normally Closed (NC)	

*switching type for condition without pressure

Discharge Nozzles (Type F007)

- The required Orifice Diameter has to be determined by an appropriate Calculation Software and Drilled out to the Calculated Orifice Size.



FiWaRec® Product Catalogue for High Pressure Fire Suppression Systems

360°-Nozzles

Article no.	Application		Nozzle Bores				External Sizes		Orifice
	CO2	Inert Gases	Bore Diameter	Thread	360°	Nozzle Cross Section	Height	Wrench Size	Orifice Diameter **
	Working Pressure	Working Pressure	b	t	d		h	w	a
	bar	bar	mm		mm	mm ²	mm	mm	mm
F0071002	90	90	Ø10	G 3/8"	8 x Ø3,6	81,4	29	24	3 – 9,5
F0071002-030									3,0
F0071002-xxx									xx,x
F0071002-095									9,5
F0071004	90	90	Ø15	G 1/2"	8 x Ø5,4	183,2	36	30	3 – 12
F0071004-030									3,0
F0071004-xxx									xx,x
F0071004-120									12,0
F0071006	90	90	Ø20	G 3/4"	16 x Ø5	314,2	46	38	4 – 16
F0071006-040									4,0
F0071006-xxx									xx,x
F0071006-160									16,0
F0071008	90	90	Ø25	G 1"	16 x Ø6,3	498,8	55	45	6 – 20
F0071008-060									6,0
F0071008-xxx									xx,x
F0071008-200									20,0
F0071010	90	90	Ø32	G 1 1/4"	16 x Ø8	804,2	64	50	8 – 25
F0071010-080									8,0
F0071010-xxx									xx,x
F0071010-250									25,0
F0071012	n.a.	90	Ø40	G 1 1/2"	24 x Ø8,2	1267,4	77	60	10 – 32
F0071012-100									10,0
F0071012-xxx									xx,x
F0071012-320									32,0
F0071014	n.a.	90	Ø50	G 2"	24 x Ø10,2	1961,1	94	80	12 – 40
F0071014-120									12,0
F0071014-xxx									xx,x
F0071014-400									40,0

n.a. = not applicable

** the required Orifice Diameter has to be Calculated by a suitable Flow Calculation Software or Method!!!

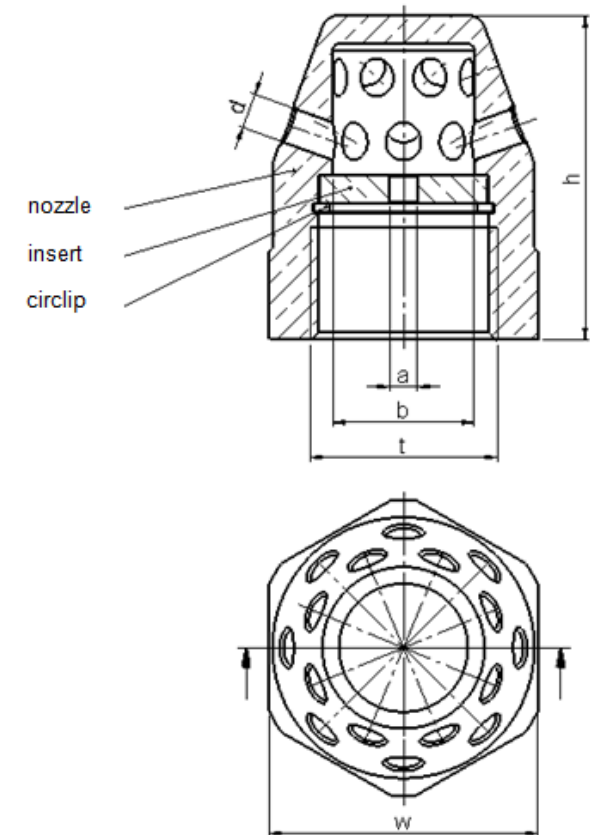

FiWaRec® Product Catalogue for High Pressure Fire Suppression Systems

180°-Nozzles

Article no.	Application		Nozzle Bores				External Sizes		Orifice
	CO2	Inert Gases	Bore Diameter	Thread	360°	Nozzle Cross Section	Height	Wrench Size	Orifice Diameter **
	Working Pressure	Working Pressure	b	t	d		h	w	a
	bar	bar	mm		mm	mm ²	mm	mm	mm
F0071001	90	90	Ø10	G 3/8"	5 x Ø4,5	79,5	29	24	3 – 9,5
F0071001-030									3,0
F0071001-xxx									xx,x
F0071001-095									9,5
F0071003	90	90	Ø15	G 1/2"	5 x Ø6,7	176,3	36	30	3 – 12
F0071003-030									3,0
F0071003-xxx									xx,x
F0071003-120									12,0
F0071005	90	90	Ø20	G 3/4"	9 x Ø6,7	317,3	46	38	4 – 16
F0071005-040									4,0
F0071005-xxx									xx,x
F0071005-160									16,0
F0071007	90	90	Ø25	G 1"	9 x Ø8,4	498,8	55	45	6 – 20
F0071007-060									6,0
F0071007-xxx									xx,x
F0071007-200									20,0
F0071009	90	90	Ø32	G 1 1/4"	9 x Ø10,7	809,3	64	50	8 – 25
F0071009-080									8,0
F0071009-xxx									xx,x
F0071009-250									25,0
F0071011	n.a.	90	Ø40	G 1 1/2"	14 x Ø10,7	1258,9	77	60	10 – 32
F0071011-100									10,0
F0071011-xxx									xx,x
F0071011-320									32,0
F0071013	n.a.	90	Ø50	G 2"	14 x Ø13,4	1974,4	94	80	12 – 40
F0071013-120									12,0
F0071013-xxx									xx,x
F0071013-400									40,0

n.a. = not applicable

**** the required Orifice Diameter has to be Calculated by a suitable Flow Calculation Software or Method!!!**

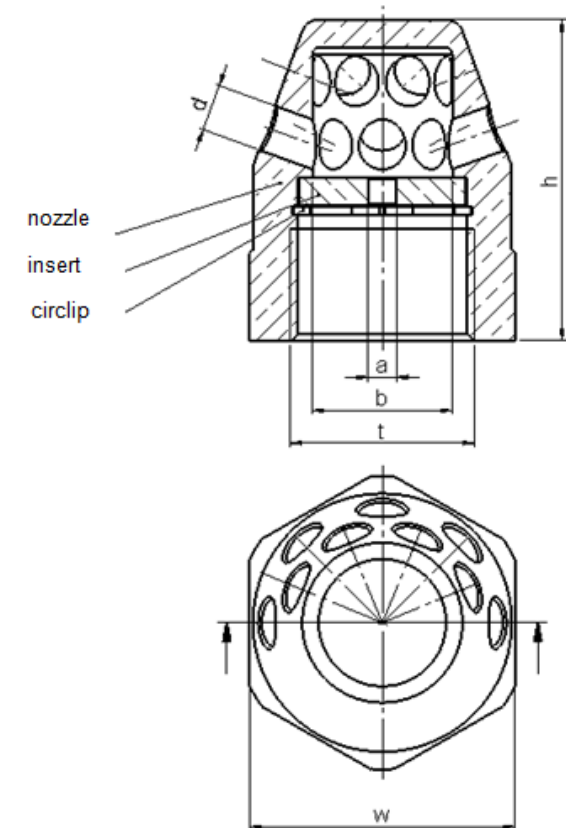

Software for Hydraulic Flow Calculation

VdS Calculation Programs for Gas Extinguishing

- for Inert Gas Systems with Orifice Plates **
- for Inert Gas Systems with Constant Pressure Regulator *
- for CO² Systems **
- for Chemical Gas Systems (HFC's - Halocarbons) **

All Software Licenses have to be purchased from VdS in Germany!

*** Customized FiWaRec Software for Inert Gases with Constant Pressure Regulator**

- Software is based on the Flow Performance of the FiWaRec F212 Regulator
- Flow Coefficients of other FiWaRec components are also implemented
- Only available for Regulator Installation directly at the Manifold (Type F2120010)

**** Standard VdS Software for Inert Gases (with Orifice Plates), CO² and Chemical Gases**

- Flow Coefficients of FiWaRec Components are available on request to implement into the existing Flow Calculation Software Version

Jensen Hughes Flow Calculation Software

- for Inert Gas Systems with Constant Pressure Regulator and Orifice Plates *
- for CO² Systems **
- for Chemical Gas Systems (HFC's - Halocarbons) **

*** Customized FiWaRec Software for Inert Gases → available in short time**

- Software Licenses will be sold by FiWaRec Valves and Regulators
- Flow Coefficients of each Components are already included
- Software will be UL/FM- tested and approved***
 - ***only if all FiWaRec Components are used
 - ***if other Products shall be used the Software Approval will not be valid

**** Standard Jensen Hughes Software for CO² and Chemical Gases**

- Software Licenses have to be purchased from Jensen Hughes
- Equivalent Length data of FiWaRec Components will be available on request to implement into the existing Flow Calculation Software Version

For more details and information like

- Datasheets
- Technical Drawings
- Instruction Manuals
- Additional Catalogues
- ...

Please send a request to: sales@fiwarec.de

Or visit the download area on our website under:

<http://fiwarec.de/de/login.html>

Copyright according to ISO 16016:

All rights reserved in the event of the grant of a patent, utility model or design.

Modifications may take place and materials may be changed without prior notice.



FiWaRec® GmbH

Europa-Allee 51
54343 Föhren

Germany